

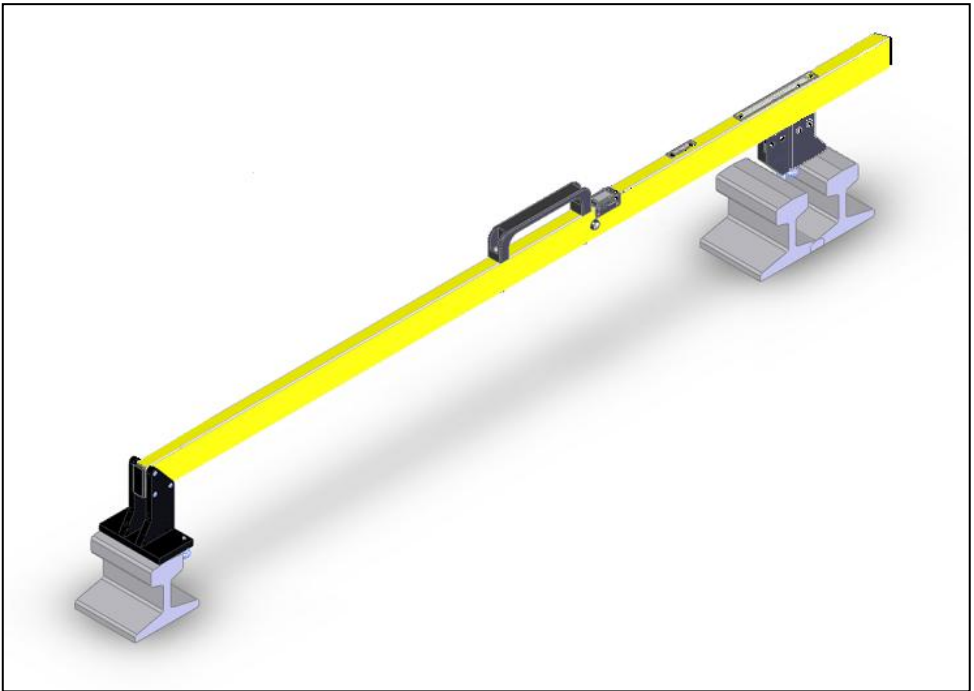

ABT5010 Inspectors Gauge



Instruction Manual

1.0 Index

- 1.0 Index
- 2.0 Overview
- 3.0 Specification
- 4.0 Getting Started
 - 4.1 Measuring Flangeway
 - 4.2 Measuring Check Gauge
 - 4.3 Measuring Track Gauge
 - 4.4 Measuring Super Elevation
- 5.0 Maintenance
 - 5.1 User Advice
 - 5.2 Every 3 months
 - 5.3 Annual

2.0 Overview

Constructed from hard-wearing GRP and Nylon, the Inspectors Gauge is electrically non-conductive, making it suitable for use in areas of 3rd and 4th rail electrification and will not interfere with the track signalling circuit.

Super-Elevation is measured electronically and is shown on an LCD display. The expected battery-life for normal, average usage is 6-12 months. The unit is powered by a standard 9v PP3 battery which can be easily replaced by the operator when required.

Track Gauge, Check Gauge and Flangeway are measured mechanically with readings displayed through a clear perspex window on a linear scale.

The gauge measures the following parameters:

Flangeway

Check Gauge

Track Gauge

Super Elevation

3.0 Specification

Weight	- 2.8kg
Size	- 1500mm x 300mm x 200mm (gauge only)
Super-Elevation	- Range: ± 200 mm Accuracy: ± 0.8 mm Resolution: 1mm
Track Gauge	- Range: 1415mm > 1470mm Accuracy: ± 0.5 Resolution: 1mm
Flange-way	- 40mm > 120mm Accuracy ± 0.5 Resolution: 1mm
Check-Gauge	- 1370mm > 1430mm Accuracy ± 0.5 Resolution: 1mm

4.0 Getting Started

To position the Inspectors Gauge onto the track begin by pulling the gauging foot towards the fixed end of the gauge. Then place the fixed end of the gauge square to the running edge of the stock rail (as indicated in Figure 1).



Figure 1

Proceed to lower the gauge towards the track until the foot can rest upon the stock rail. Whilst holding the gauge release the Gauging Foot across to the running edge of the opposite stock rail (as indicated in Figure 2).



Figure 2

4.1 Measuring Flangeway

The Flangeway measurement is the dimension between the running edge of the stock rail and the rear face of the adjacent switch rail (as indicated in Figure 3).



Figure3

To measure flangeway pull the Flangeway Foot manually across to the rear face of the switch rail (as indicated in Figure 4).



Figure 4

The measurement readout will be displayed on the upper half of the Scale Window (as indicated in Figure 5).



Figure 5

Switch Opening can be measured using the same method as above.

4.2 Measuring Check Gauge

Check Gauge is the dimension between the rear face of an open switch and the running edge of the closed switch (as indicated in Figure 6).



Figure 6

This measurement is taken from the same position as Flangeway Measurement, the readout will be displayed on the lower half of the Scale Window (as indicated in Figure 7).



Figure 7

4.3 Measuring Track Gauge

Track Gauge or rail gauge is the distance between the inner sides of the heads of the two stock rails (as shown in Figure 8).

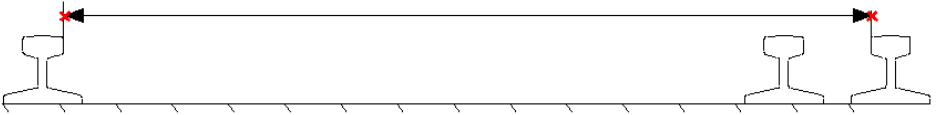

Figure 8

To measure Track Gauge ensure the Gauging Foot is square against the stock rail (as shown in figure 9).

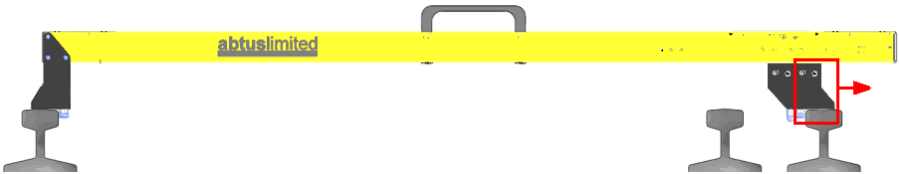

Figure 9

The measurement readout will be displayed with in the Small Scale Window and will be indicated by the black line situated in the centre of the window (as shown in Figure 10).

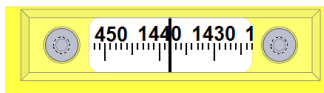

Figure 10

4.4 Measuring Super Elevation

To measure super elevation press the white button located on the side of the gauge, a measurement will appear on the screen above the white button (as shown in Figure 11)



Figure 11

5.0 Maintenance

5.1 User Advice

The ABT5010 is a piece of precision measurement equipment. Whilst it has been designed for use in an engineering environment due care should be taken not to cause damage to the equipment when in operation, storage or transit. Excessive trauma to the moving parts of the gauge may invalidate the calibration and lead to possible measurement inaccuracies.

5.2 Every 3 Months

Visually inspect the ABT5010 for signs of damage. If necessary, contact your local distributor for help.

5.3 Annual

The ABT5010 must be returned annually for re-calibration to ensure measurements are within specification.

The condition of all components will be checked at this time and replaced as required.