

## The Abtus Range of Track Geometry products include:

- ABT 4530 – Alignment Trolley
- ABT 4370 – Data Logging Trolley
- ABT 4650 – Route Scan
- ABT 4640 – Laser Height and Stagger Gauge
- ABT 4610 – Datum Offset Gauge
- ABT 4505 – Data Logging Switch Gauge
- ABT 4190 – Platform and Offset Gauge
- ABT 4050 – Collapsible Platform Gauge
- ABT 4071 – 3<sup>rd</sup> Rail Gauge Folding
- ABT 4070 – 4<sup>th</sup> Rail Inspectors Gauge
- ABT 4160 – Lead Rail Inspectors Gauge (LUL Type)
- ABT 4580 – 6' Relative Level Gauge
- ABT 4216 – 4'/6' Retractable Cross Level Transfer Gauge
- ABT 4090 – Side-Cut and Railhead Gauge
- ABT 4590 – NR4 Stepped Sidewear Gauge
- ABT 4080 – Trackspread Gauge
- ABT 4660/1 – P8 Profile SE Gauges
- ABT 4269 – Combination Gauge

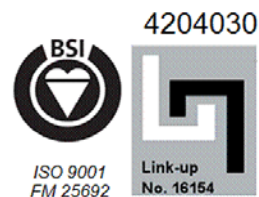



# ABT4505 Data-Logging Switch Gauge

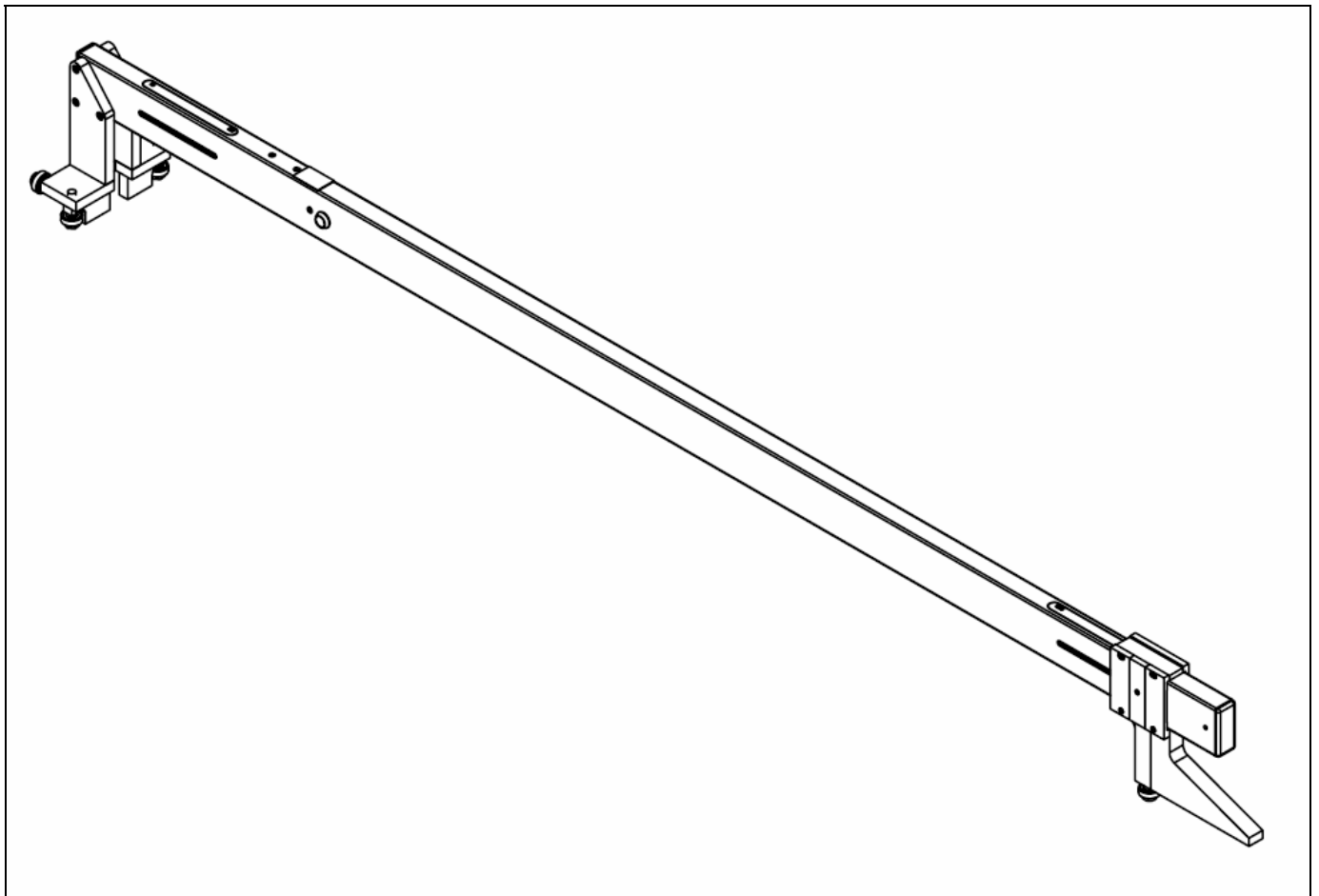

## Instruction Manual

# 1.0 Index

<b>1.0</b>	<b>Index</b>	<b>1</b>
<b>2.0</b>	<b>Item List</b>	<b>2</b>
<b>3.0</b>	<b>Specification</b>	<b>2</b>
<b>4.0</b>	<b>Getting Started</b>	<b>3</b>
4.1	Overview	3
4.2	Assembly	3
4.3	Bluetooth Connection	3
4.4	Recording Data	5
<b>5.0</b>	<b>Software Features</b>	<b>8</b>
5.1	Design Survey	8
5.2	Save as Image	10
5.3	View Results	10
5.4	File Types	10
5.5	Transferring Recorded Data Files to a PC	11
<b>6.0</b>	<b>Maintenance</b>	<b>12</b>
6.1	Before Each Use	12
6.2	Every 3 Months	12
6.3	Annual	12
<b>7.0</b>	<b>Measurement Characteristics</b>	<b>13</b>
7.1	Gauge	13
7.2	Check-Rail Gauge	13
7.3	Flange-Way	13
7.4	Super-Elevation	13
<b>8.0</b>	<b>Trouble shooter</b>	<b>14</b>
8.1	Tips for Good Recording	14
8.2	No Power	14
8.3	Can Not Connect	14
8.4	Can Not Save Data	14

## 8.0 Trouble shooter

### 8.1 Tips for Good Recording

The ABT4505 is a very accurate piece of equipment – many of the parameters that it measures rely on extremely sensitive sensors. While every reasonable effort has been made to make it ‘railway proof’, users should treat it with extreme care.

### 8.2 No Power

Check that all the batteries are fully charged. The DLSSG takes approximately **4hours** to charge and the Control Unit takes approximately **2hours**.

### 8.3 Can Not Connect

The connection between the Control Unit and the Trolley is via Bluetooth. Obstacles such as metal and water (the human body is mostly water!) can degrade wireless signals – ensure that nothing is restricting the signal.

Ensure that all batteries are fully charged (see section 4.1 for more information on the batteries).

### 8.4 Can Not Save Data

Check that the SD Card is not set to ‘Read-Only’ (the small white switch on the side of the card).

## 7.0 Measurement Characteristics

### 7.1 Gauge

Range	1315mm>1465mm
Accuracy	±0.75mm
Resolution	0.1mm

Gauge (Running Gauge) is measured as the distance between the outside face of the bearings on the fixed side of the gauge to the outside face of the bearing on the sliding arm on the opposite side. Gauge is measured through the centre line of the DLSG.

### 7.2 Check-Rail Gauge

Range	1290mm>1440mm
Accuracy	±0.75mm
Resolution	0.1mm

Check-Rail Gauge is measured as the distance between the outside face of the bearings on the fixed side of the gauge to the inside face of the bearing on the sliding arm on the opposite side. Check-Rail Gauge is measured by subtracting the distance from the Check-Rail to the Running Rail from the Running Gauge.

### 7.3 Flange-Way

Range	22mm - 175mm
Accuracy	±0.75mm
Resolution	0.1mm

Flange-Way is measured as the distance between the outside face of the bearing on the sliding arm to the inside face of the same bearing. Flange-Way is a compound measurement – the DLSG calculates the measurement after the user has followed the correct sequence.

### 7.4 Super-Elevation

Range	±200mm
Accuracy	±1.2mm
Resolution	0.1mm

Super Elevation (SE) is measured across the running rails and is displayed as height differential between the high and low rail in millimetres. A positive SE reading is when the right rail is higher than the left.

## 2.0 Item List

1. Data Logging Switch Gauge (DLSG)
2. Control Unit
3. Carry Case
4. Instruction Manual
5. DLSG Charger
6. Control Unit Charger

## 3.0 Specification

Weight	On track(DLSG) - (Control Unit) In Box	2.5kg 0.2kg -
Physical Dimensions	On Track(DLSG only) - In Box	1655 x 170 x 145 (mm) -
Operating Temperature		-10°C to + 50°C (-4°F to 122°F)
Environmental Rating		IP54
Battery Life	DLSG - Control Unit	Up to 8 hours Up to 6 hours
Operating System		
PC Connectivity		USB Bluetooth Wireless LAN

## 4.0 Getting Started

### 4.1 Overview

The Abtus ABT4505 Data-Logging Switch Gauge has been developed for the electronic capture of geometry data within the Switch & Crossing area of the Permanent-Way.

A hand-held control unit allows the operator to choose from a selection of customised, pre-formatted measurement routines. The software then displays on-screen graphical instructions to lead the operator through the measurement routine.

Subsequent geometry data is sent from the gauge via a wireless connection and is displayed on the screen of the control unit. Recorded files can be reviewed on the control unit or downloaded to a PC.

The use of wireless technology means that there are two separate batteries in your ABT4505:

- DLSG
- Control Unit

Both of these batteries must be fully charged for the DLSG to function for the specified operating period

Please review Section 8.1 prior to using your ABT4505 for the first time.

### 4.2 Assembly

Upon receipt of your ABT4505 no assembly is required.

### 4.3 Bluetooth Connection

Before recording can start, a Bluetooth connection must be made between the Control Unit and the ABT4505 – imagine this step is like plugging in the cable:

## 6.0 Maintenance

### 6.1 Before Each Use

The following routine checks should be carried out immediately prior to use:

1. Ensure all batteries are fully charged (see section 4.1 for more information)
2. Wipe any accumulated grime/grease from the DLSG.

### 6.2 Every 3 Months

Visually inspect the ABT4505 for signs of damage. If necessary, contact your local distributor for help.

### 6.3 Annual

The ABT4505 must be returned to Abtus Ltd annually for re-calibration to ensure measurements are within specification.

The condition of all components will be checked at this time and replaced as required.

- \*.CSV
- \*.sec

The CSV file is in a standard format which will open in almost any software package (e.g. Excel, Word, Notepad etc). This file contains all the Start and Finish information along with all the recorded data in an easy to read layout.

The SEC file contains exactly the same information as the CSV file but is encrypted. It is possible to view this 'secure' file through the 'View Results' screen (see section 5.2) however it is not possible to edit it. This file is tamper-proof and is suitable for auditing purposes.

## 5.5 Transferring Recorded Data Files to a PC

Recorded Data is stored on the control unit in the following location:

\\SD Card\Abtus Gauge Interface\Recorded Data\DLSEG\....

Data can be transferred in one of two ways:

### ActiveSync

1. Connect the control unit to the PC using either a USB cable or a Bluetooth connection
2. Open Windows Explorer on the PC and in My Computer, select Mobile Device
3. Navigate to the above location and copy the Data Files as required

(Depending on the PC's Operating System, the PC may try to download ActiveSync from the internet when it has sensed the connection between the Control Unit and the PC – follow the on-screen instructions to complete this step)

### SD Card Reader

1. Remove the SD card from the control unit (always power down the control unit before removing the SD card) and insert it into the PC
2. Navigate to the above location on your PC using Windows Explorer and copy the Data Files as required

Abtus Ltd can supply SD Card readers that connect to a USB port.

1. Turn on the Control Unit (Please refer to manufacturers own operating manual for details of operation as control unit models may vary) – wait until the Windows operating system has fully loaded
2. Load the Abtus Gauge Interface software from the Start Menu – the software launches directly to the ‘Connection’ screen
3. Ensure that the gauge is powered by depressing the ‘Power Button’ See *Figure 1* – The blue light on the top of the DLSG should now be lit.

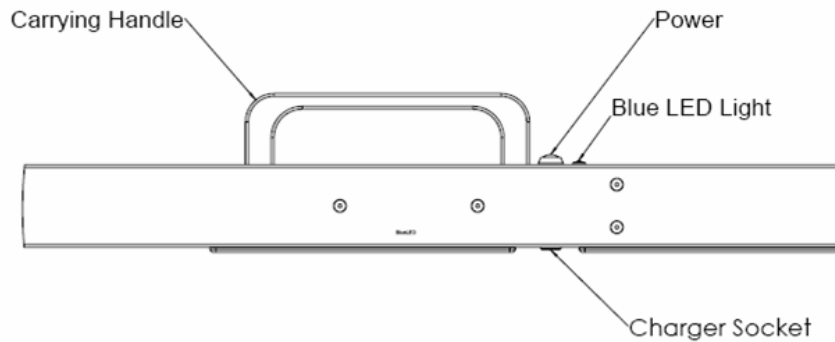

Figure 1

4. Select the desired gauge from the list<sup>1</sup> and tap the ‘Connect’ button
5. Please be patient while the Control Unit makes the connection
6. When the connection has been made, the ‘Options’ screen is displayed, see *Figure 2*.

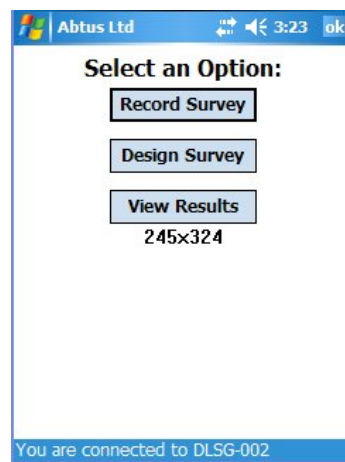

Figure 2

7. If the connection fails, see Section 8.0 for help

<sup>1</sup> The Abtus Gauge Interface software is common to all Abtus Bluetooth products and so it is possible to ‘Pair’ the Control Unit with a number of different gauges

## 4.4 Recording Data

The Abtus Gauge Interface software provides a versatile framework in which to record and analyse track data. These features are covered in depth in Section 5.0 this section will only describe the steps necessary to start a recording.

1. Select the 'Record Survey' Box from the 'Options' screen
2. Choose the type of Switch Layout to be recorded from the left-hand box then in the right hand box 'Tap & Hold' on the desired survey format, a 'Start' box will appear as shown in *Figure 3*. Tap 'Start' to continue

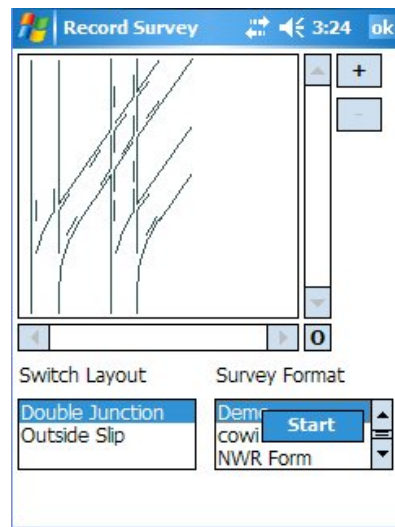

Figure 3

3. Now in the 'Session Details' screen use the keyboard at the bottom of the screen to give the survey a filename. If desired select the 'More' box to add additional information such as Start Description. Upon completion of the filename tap the keyboard icon at the bottom of the screen to remove the keyboard and tap 'Start Recording'
4. The DLSG is now in recording mode. The control unit displays a diagram of the Switch & Crossing layout together with the measurement routine. Beneath this is the Command Box
5. For some measurements, an instruction note may have been entered. If this is the case, this will be shown in the Command Box. To proceed to the next step, tap anywhere in the Command Box
6. The Command Box will now display a graphical instruction on how to place the gauge on the track, see *Figure 5*

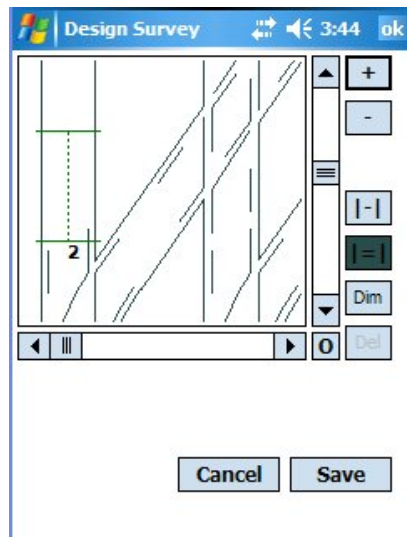

Figure 9

### Saving a Measurement Routine

1. If the measurement parameter options are visible at the bottom of the screen, hide them by tapping a blank area inside the switch layout diagram
2. Select 'Save' from the bottom right hand of the screen, see *Figure 9*
3. Confirm the name of the measurement routine and tap 'Ok' next to the text box

## 5.2 Save as Image

To save an image (in \*.jpg format) of the design survey, tap and hold in the 'Survey Format' box to bring up an options menu. Select 'Save as Image' – this saves an image of the design survey to the following location:

\\SD Card\Abtus Gauge Interface\System\DL SG\Survey Formats\....

Transfer this image to a PC to include it in your survey reports.

## 5.3 View Results

To review recorded Data Files tap the 'View Results' button in the 'Options' screen. Select the file you wish to review from the drop down box at the bottom of the screen. Toggle between file types (see section 5.3) using the button in the bottom right of the screen.

## 5.4 File Types

The ABT 4505 automatically saves two files for each recording. The file types are:

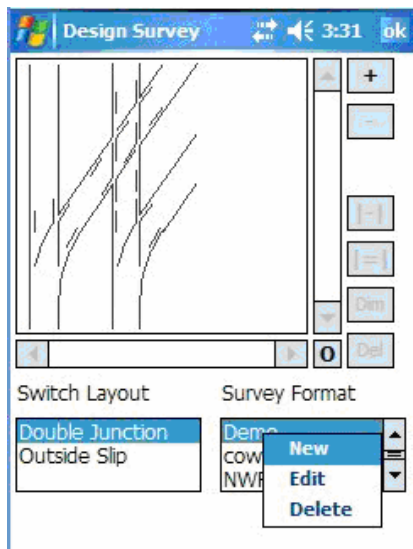

Figure 7

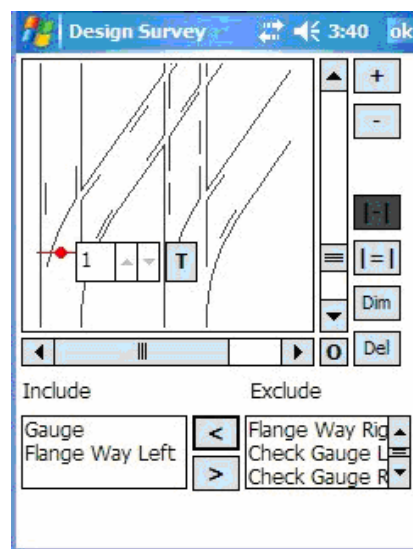



Figure 8

### Create a Single Measurement Survey Location

1. To add a single measurement Survey Location, select the  icon from the right of the screen
2. Draw a line across the track where you want the measurement to take place
3. A line will indicate where on the switch layout the measurement will take place. This is accompanied by a number which indicates the order in which the measurements will be taken
4. To set which measurement parameters are required, select a Parameter from the 'Exclude' box and add it using the '<' button to move it to the 'Include' box. See *Figure 8*

### Create a Multiple Measurement Survey Location

1. Multiple measurement locations can be added to the survey by selecting the  icon. This can be used for commands such as "Measure track gauge at each sleeper". Draw a line across the track at the position of the first measurement, draw another line at the position of the last measurement, see *Figure 9*
2. Edit the measurement parameters in the same way as for a single measurement survey location

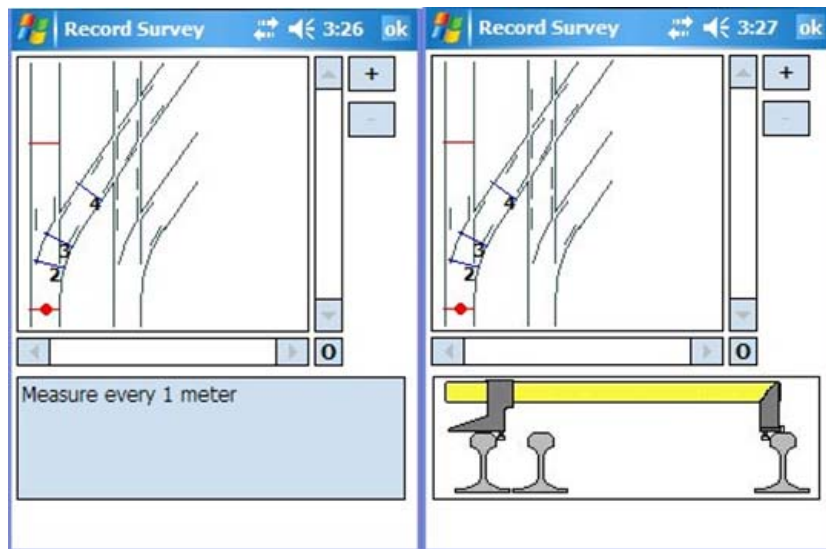

Figure 4

Figure 5

7. When you are confident that the DLSG is in the correct position, tap anywhere inside the Command Box. Some parameters such as 'Flange-Way' and 'Check Gauge' require more than one operation per position, if this is the case continue to follow the graphical instructions in the Command Box until the measurement results are displayed, see *Figure 6*. Tap Command Box again to continue

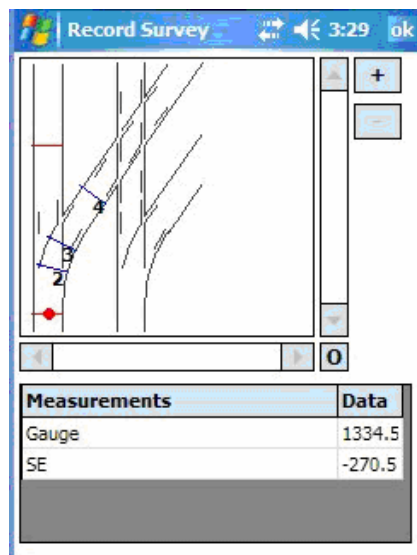

Figure 6

8. The Command Box now provides the options to 'Redo' the measurement or proceed to the 'Next' survey location. In some cases (as in the highlighted survey location shown in *Figure 6*), a number of measurements are required between two points. To include additional measurement, tap 'Add'

9. Continue through the measurement routine by following the instructions from the Command Box. After the last measurement has been taken, 'Next' will be replaced by 'Finish'. Tap 'Finish' to complete the recording session
  
10. The 'Session Details' screen is now displayed allowing the operator to enter a 'Finish Description'. Hide the keyboard by tapping the icon at the bottom of the screen and then tap 'Finish' to save the survey and return to the 'Options' screen

## 5.0 Software Features

### 5.1 Design Survey



The ABT4505 Data-Logging Switch Gauge has the facility for the user to design a measurement routine specific to their requirements or a local standard.

To edit or create a measurement routine, select 'Design Survey' from the 'Options' screen.<sup>2</sup>



#### Create/Edit Measurement Routine

1. To create/edit a measurement routine, select the desired layout from the options in the 'Switch Layout' box
2. Tap and hold in the 'Survey Format' box to reveal another list of options as shown in *Figure 7*. Select the required option

#### Changing the View

1. It is possible to zoom in or out in order to see the survey in greater detail. This can be done by selecting the  or  buttons
2. Scroll the view using the horizontal and vertical scroll bars
3. To return to 'Full Screen', tap the  button

#### Select and Edit an Existing Survey Location

1. Select a Survey Location by tapping the screen at the desired location – the location is now highlighted in red
2. The position of the Survey Location can be moved by dragging it
3. To change the order of the selected location, use the  control
4. To include a written instruction for the measurement location, tap the 'T' button situated next to the survey location. To confirm the text, tap 'Ok'
5. To remove the selected survey location, tap the  button

<sup>2</sup> It is possible to connect 'Offline' to enter the Design Survey environment. 'Offline' means that there is no requirement for the gauge to be present and that no Bluetooth connection is made. To connect 'Offline', tick the 'Connect Offline' box on the 'Welcome' screen before connecting.