

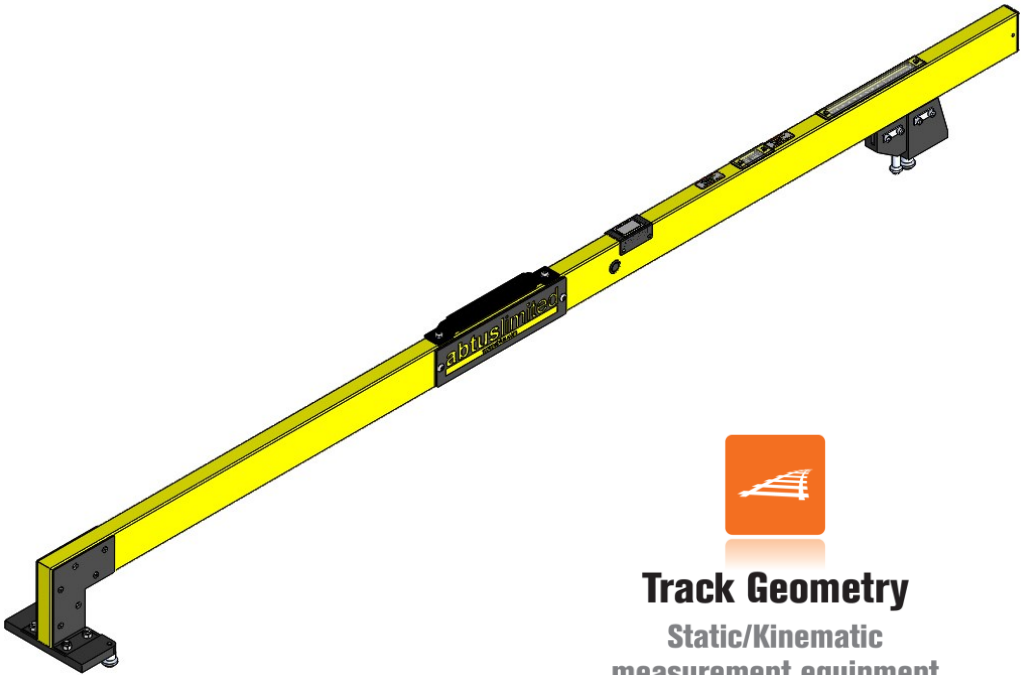

ABT 5000 Series & 4670 Gauges



Track Geometry
Static/Kinematic
measurement equipment
for track alignment
and inspection.

Instruction Manual

1.0 Index

- 1.0 Index
- 2.0 Overview
- 3.0 Technical Specification
- 4.0 Functionality
 - 4.1 Track Gauge
 - 4.2 Flangeway
 - 4.3 Check Gauge
 - 4.4 Cant
 - 4.5 P8 Measurement
- 5.0 Maintenance
 - 5.1 User Advice
 - 5.2 Every 3 Months
 - 5.3 Annual
 - 5.4 Replacing the PP3 Batteries

2.0 Overview

Abtus track gauges have been designed with a sprung gauging foot, with all measurements displayed on the useable end of the gauge, ensuring improved repeatability and accuracy of measurements, whilst minimising potential for user error.

Constructed from hard-wearing glass reinforced plastic (GRP) and polyvinyl chloride (PVC), the 5000 series gauges including the 4670 (S&C) are all electrically non-conductive and will not interfere with the track signalling circuit. These therefore are suitable for use in areas of 3rd and 4th rail electrification. All the 5000 series gauges including the 4670 are available in both imperial and metric versions for multiple track widths and can be provided with alternative wheel profiles. The standard mushrooms measure 14mm below the top of the rail (TOR), alternative P-points should be specified when an order is placed.

Super-Elevation is measured electronically and is shown on an LCD display. The expected battery-life for normal, average usage is 12 months. The unit is powered by 2 standard 9v PP3 battery which can be easily replaced by the operator when required.

Track Gauge, Check Gauge and Flangeway are measured mechanically with readings displayed through a clear polycarbonate window on a linear scale.

For visual inspection of the Switch Rail wear profile, the Inspectors gauge is supplied with P8 wheel profiles fitted to the upper side of the beam.

3.0 Technical Specification

Abtus No.	ABT 5000	ABT 5010	ABT 5020	ABT 4670
NR Type	NR 1	NR 2	NR 3	NR 5
P8 Profile	-	-	Y	Y
Track Gauge	Y	Y	Y	Y
Track Cant	Y	Y	Y	-
Check Rail Flangeway/Free Wheel Clearance	-	Y	Y	Y
Track Gauge Range	From Nominal -25mm to +55mm	From Nominal -25mm to +55mm	From Nominal -25mm to +55mm	From Nominal -25mm to +55mm
Track Gauge Accuracy	±1mm	±1mm	±1mm	±1mm
Track Gauge Resolution	1mm	1mm	1mm	1mm
Track Cant Range	±199mm	±199mm	±199mm	-
Track Cant Accuracy	±1mm	±1mm	±1mm	-
Track Cant Resolution	0.1mm	0.1mm	0.1mm	-
Flangeway Range	-	40mm -120mm	40mm -120mm	40mm -120mm
Flangeway Accuracy	-	±1mm	±1mm	±1mm
Flangeway Resolution	-	1mm	1mm	1mm
Check Gauge Range	-	From Nominal to -70mm	From Nominal to -70mm	From Nominal to -70mm
Check Gauge Accuracy	-	±1mm	±1mm	±1mm
Check Gauge Resolution	-	1mm	1mm	1mm
Gauge Weight	2.8 Kg - 3.2 Kg *	2.8 Kg - 3.2 Kg *	2.8 Kg - 3.2 Kg *	2.8 Kg - 3.2 Kg *
Gauge Length	Nominal TG + 215mm	Nominal TG + 215mm	Nominal TG + 215mm	Nominal TG + 215mm
Gauge Width	136mm	136mm	136mm	136mm
Gauge Height	160mm	160mm	205mm	205mm

Table 1-Technical Specification table

*Dependent upon Gauge Type & Gauge Size

Gauges manufactured in compliance with NR/L3/TRK/4900 Track Gauge Specification

Reference number information – i.e.ABT5020-1600g

Gauge T type	Nominal Track Gauge
ABT 5020	1600mm

4.0 Functionality

4.1 Track Gauge

Track gauge or rail gauge is the distance between the inner sides of the heads of the two stock rails, as shown in Figure 1.

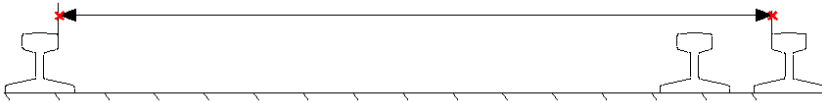

Figure 1 - Track Gauge/ Rail Gauge

Once the gauge has been positioned in the track, the Track Gauge reading can be read from the window indicated in Figure 2.

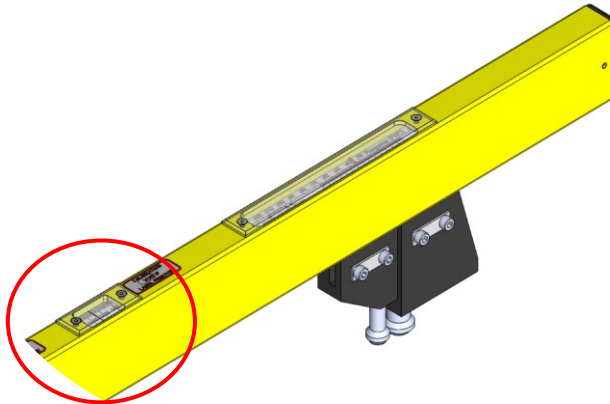

Figure 2 - Track Gauge Reading

4.2 Flangeway

The flangeway measurement is the dimension between the running edge of the stock rail and the rear face of the adjacent switch rail, as shown in Figure 3.



Figure 3 - Flangeway

Flangeway (FWC) can be read from the window on the upper side of the cross beam and can be clearly seen on the top scale as shown in Figure 4. When the two mushroom headed pins are together, the minimum flangeway measurement is 35mm.

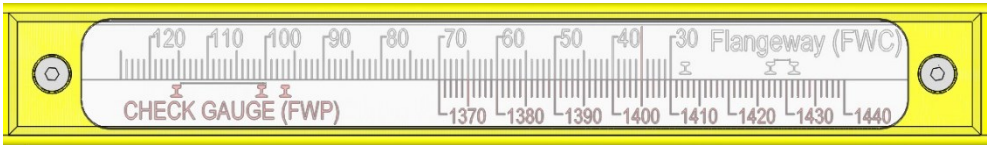

Figure 4 - Flangeway/ Check Gauge Scale

4.3 Check Gauge

Check gauge is the dimension between the rear face of an open switch and the running edge of the closed switch, as shown in Figure 5.



Figure 5 - Check Gauge

Check Gauge (FWP) can be read from the same window as the flangeway and can be clearly seen on the bottom scale as shown in Figure 4.

4.4 Cant

To measure Cant, press the button located on the side of the gauge, a measurement will appear on the screen above. Wait for a few seconds before taking a reading to ensure that the gauge is settled. The display will turn off within a minute of pressing the button.

4.5 P8 Measurement

The P8 wheel profiles located on the upper face of the cross beam is to aid the visual inspection of the switch rail wear when the gauge is turned upside down as shown in Figure 6.

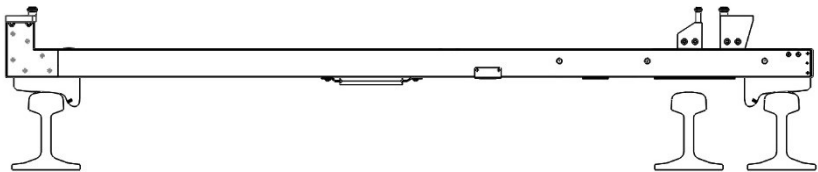

Figure 6 - P8 Wheel Profile

This is to be used during routine supervisors and track maintenance engineers' visual track inspection.

It is used to visualise the wheel flange path along a switch rail to determine if wear or damage is leading to conditions that require a more detailed inspection, that is where contact between switch rail and wheel flange is below the 60° indicator line.

5.0 Maintenance

5.1 User Advice

The ABT 5000 series gauges are a piece of precision measurement equipment. Whilst it has been designed for use in an engineering environment due care should be taken not to cause damage to the equipment when in operation, storage or transit. Excessive trauma to the moving parts of the gauge may invalidate the calibration and lead to possible measurement inaccuracies.

5.2 Every 3 Months

Visually inspect the ABT 5000 series gauges for signs of damage. If necessary, contact your local distributor for help.

5.3 Annual

The ABT 5000 series gauges must be returned annually for re-calibration to ensure measurements are within specification.

The condition of all components will be checked at this time and replaced as required.

5.4 Replacing the PP3 Batteries

To replace the PP3 batteries, carefully remove the battery compartment from the front of the gauge as shown in Figure 7. Visually inspect the gasket for signs of wear/damage and replace if necessary, contact your local distributor for help.

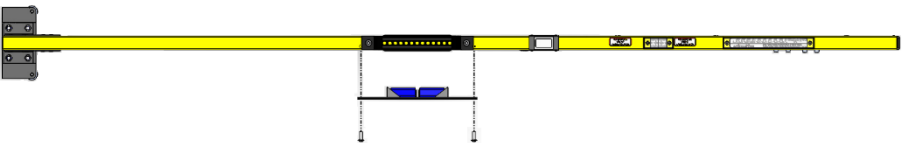

Figure 7 - Battery Replacement