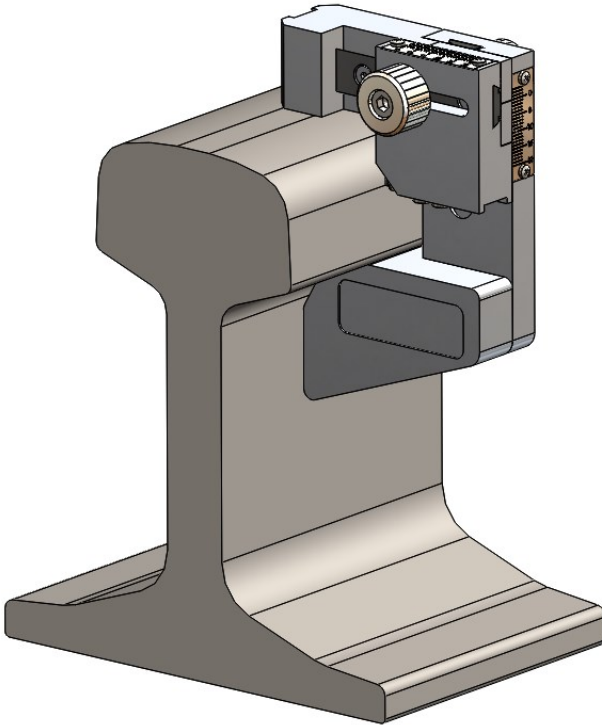


# ABT5200 Sidecut Gauge



## Instruction Manual

# 1.0 Index

<b>1.0</b>	<b>Index</b>	<b>1</b>
<b>2.0</b>	<b>Overview</b>	<b>1</b>
<b>3.0</b>	<b>Specification</b>	<b>1</b>
<b>4.0</b>	<b>Getting Started</b>	<b>2</b>
<b>4.1</b>	<b>Measuring Sidewear</b>	<b>4</b>
<b>4.2</b>	<b>Measuring Headwear</b>	<b>5</b>
<b>5.0</b>	<b>Maintenance</b>	<b>7</b>
<b>5.1</b>	<b>User Advice</b>	<b>7</b>
<b>5.2</b>	<b>Every 3 Months</b>	<b>7</b>
<b>5.3</b>	<b>Annual</b>	<b>7</b>

## 2.0 Overview

Constructed from a combination of hard-wearing stainless steel and lightweight aluminium, the ABT5200 Sidecut Gauge is a compact solution to measuring side and headwear.

The side and headwear are measured mechanically on a pair of linear stainless steel scales via a horizontal and vertical slide respectively.

The gauge measures the following parameters:

- Sidewear
- Headwear

## 3.0 Specification

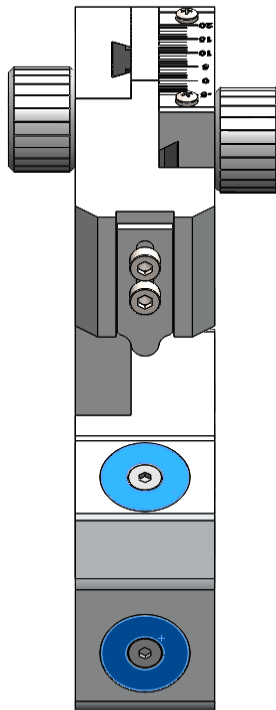
<b>Weight</b>	-	0.36kg
<b>Size</b>	-	112mm x 80mm x 49mm
<b>Sidewear</b>	-	Range: -5mm/ + 20mm Accuracy: $\pm 1$ mm Resolution: 1mm
<b>Headwear</b>	-	Range: -3mm/ + 20mm Accuracy: $\pm 1$ mm Resolution: 1mm

## 4.0 Getting Started

When picking a measurement point, it is important to consider the following points as they can cause an inaccuracy;

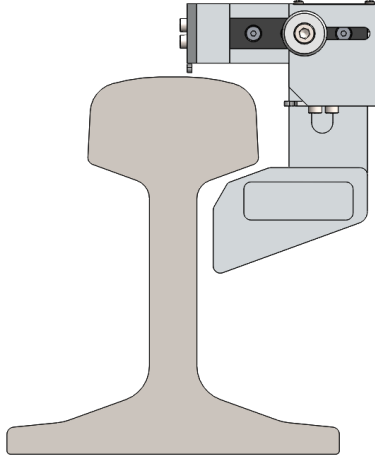
- Location of welds or branding marks.
- Excess loose rust, dirt and grease.

Once a suitable measuring position has been chosen, the gauge can be attached to the rails. The gauge has 2 locating magnets, as shown in Figure 1, which will allow it to stay connected to the rail; leaving the user's hands free to take the measurements.

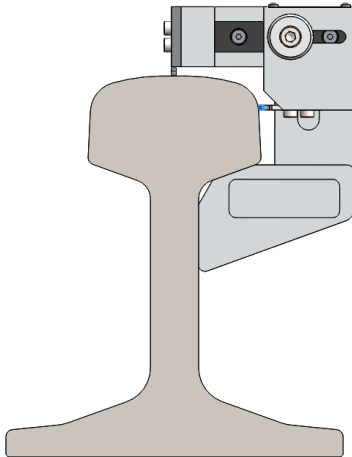


*Figure 1*

Figure 2 shows the mating faces of the rail and the gauge. Once the magnets have adhered themselves to the faces on the rail, the gauge will hold itself in the measuring position, as shown in figure 3.



*Figure 2*

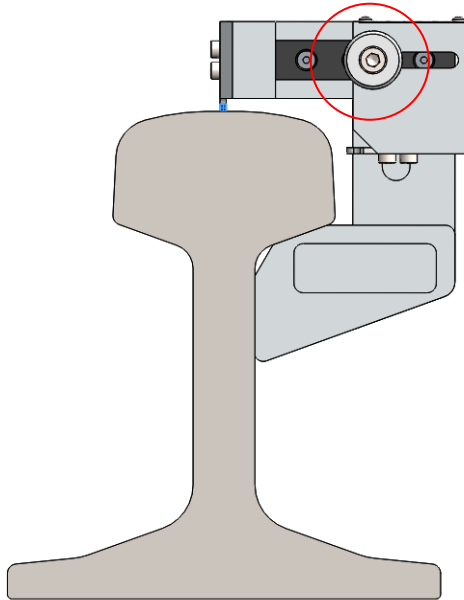


*Figure 3*

## 4.1 Measuring Sidewear

The sidewear measurement is the amount of wear caused on the side of the profile by the contact of the wheel on the running rail.

To measure the sidewear, ensure the gauge is fully in contact with the rail as shown previously then the horizontal measuring slide can be adjusted as shown in figure 4.



*Figure 4*

Once the lower corner of the measuring pin is in contact with the worn edge of the profile, the measurement can be taken from the sidewear scale on the top of the gauge, as shown in figures 5 and 6. The sidewear measurement is given as mm worn since the rail was new.

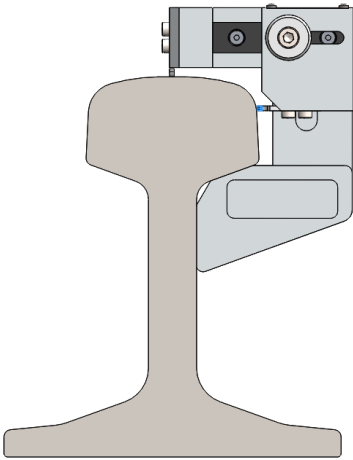


Figure 5

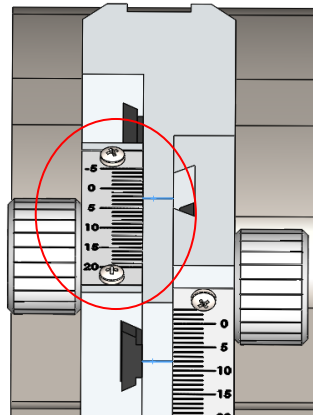


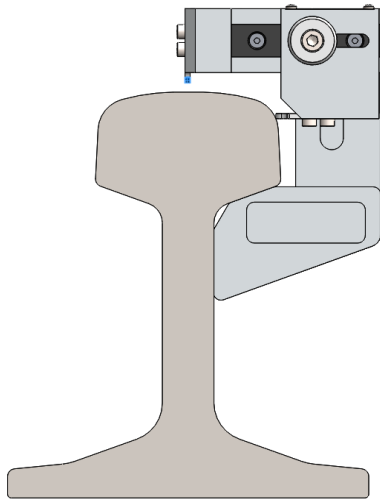
Figure 6

## 4.2 Measuring Headwear

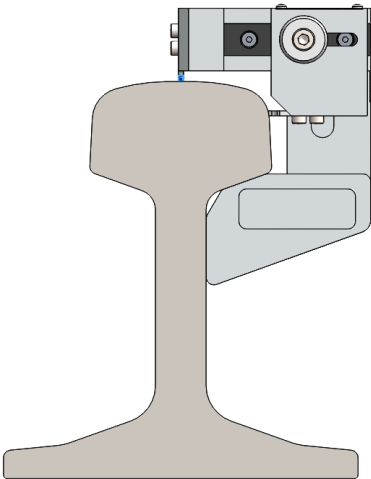
Headwear is the deterioration of the top of the profile as a result of the friction between moving wheel and the rail.

To measure headwear, again ensure the gauge is fully in contact with the rail, please push the knob or the sliding mechanism directly and not the body of the gauge as this can cause the gauge lockup, then the vertical headwear slide can be adjusted until the measuring pin is touching the top of the rail. The headwear scale on the side of the gauge will display the measurement for that position.

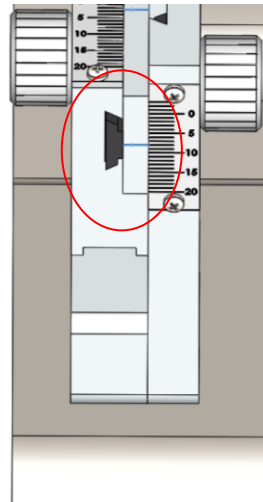
Headwear is also displayed in mm worn since the rail was new.



*Figure 7*



*Figure 8*



*Figure 9*

## 5.0 Maintenance

### 5.1 User Advice

The ABT5200 is a precise measurement equipment. Whilst it has been designed for use in an engineering environment, due care should be taken not to cause damage to the equipment when in operation, storage or transit. Excessive trauma to the moving parts of the gauge may invalidate the calibration and lead to possible measurement inaccuracies.

### 5.2 Every 3 Months

Visually inspect the ABT5200 for signs of damage. If necessary, contact your local distributor for help.

### 5.3 Annual

The ABT5200 must be returned annually for re-calibration to ensure measurements are within specification.

The condition of all components will be checked at this time and replaced as required.